



CW-5HD

Operation Manual cev.fr

IDX Company, Ltd.

Table of contents

I. SAFETY INSTRUCTIONS	2
II. CONTENTS	5
1. PRODUCT OVERVIEW	5
2. GETTING STARTED	6
2.1. CW-5HD TX (Transmitter)	6
2.2. CW-5HD RX (Receiver)	8
3. LED INDICATOR	10
3.1. LED indicator functions.....	10
3.2. CW-5HD link initialisation	11
4. Selection of frequencies and transmit output power	12
4.1. Service frequencies and output power	13
4.2. Automatic frequency selection.....	12
5. Link modes - UNICAST/MULTICAST	14
5.1. UNICAST mode (1:1 communication)	14
5.2. MULTICAST mode (1:n communication)	15
6. Operation guide.....	15
6.1. Set up	15
6.2. Operating procedures.....	15
6.3. Unstable reception.....	16
6.4. Back-up power failure function	17
6.5. Power through function	17
7. Notes on use.....	17
III. SPECIFICATIONS	18
8. CW-5HD TX	19
9. CW-5HD RX	20

I. SAFETY INSTRUCTIONS

To use this product safely and correctly please follow the safety precautions set out below. Product misuse may cause fire, shock, injury, product failure or other hazards. Please read this manual prior to using your CW-5HD and retain for future reference.

 Caution Fire or electric shock may cause injury or other accidents.	
<ul style="list-style-type: none">• Before using an external power supply, always check that the voltage is within the specified range and that the polarity of the connector is correct, as this will avoid smoke or fire.	<ul style="list-style-type: none">• Do not attempt to disassemble, modify or repair this product yourself. That may cause fire or electric shock. Please refer inspection and repair services to your dealer or local IDX office.
<ul style="list-style-type: none">• Do not use this product near water or in high humidity environments. This may cause fire or electric shock.	<ul style="list-style-type: none">• In case of damage, smoke, unusual smell or other unexpected situations, stop use immediately and consult your dealer or local IDX office.
<ul style="list-style-type: none">• Turn the power switch off if any liquid or substance gets inside the product. Continuous use under such condition may cause shortage, fire or electric shock.	<ul style="list-style-type: none">• When a battery is mounted on CW-5HD, or CW-5HD is mounted on a video camera or on a monitor, please ensure that they are correctly and firmly locked.



Caution - continued

Fire or excessive heat may cause injury or damage to surroundings.

●If ventilation openings are blocked, this may cause excessive heat or damage.

●After long periods of continuous use, the case of the unit may be warm to touch.

●Using the CW-5HD in an environment with a lot of moisture, soot or dust may cause excessive heat or electric shock

●Do not stare at LED lights on the side panel of CW-5HD, as this may cause damage to the eyes.

●Do not place this product on an uneven surface or one with vibration. It may cause failure or damage.

Caution on the use of this product and radio waves

- This product is approved for technical standard compliance certification as a wireless device of radio stations with low antenna power specified under international and U.S. FCC Radio wave regulations. Therefore a license for radio station use is not required to operate this product.
- CW-5HD uses 5GHz band radio frequencies and it has been shown not to interfere with medical devices. However, when in use, it is recommended to keep the CW-5HD at least 30cm (12in.) away from medical devices to ensure safety.

II. CONTENTS

1. Product Overview

The CW-5HD is a wireless transmission device which transmits HD SDI video and SDI audio with 5GHz band radio frequencies. CW-5HD TX is the transmitter, and connects to a video source such as a video camera. CW-5HD RX is the receiver, and connects to a monitor, for example. Video and audio from the video source can be seen / listened to from a distance without cable connections. Where a direct line-of-view is offered between CW-5HD TX and RX, the signals can be transmitted up to 50m (with the transmit output power in HIGH mode).

Other features

- *Supports HD-SDI/SD-SDI input and output.*
 - *Transmitting HD video (1080i, 1080p, 720p) and SD video (525i/625i)*
 - *Supporting SDI embedded audio. (Audio CH1 and CH2 only)*
 - *Transmission delay is 1m/sec maximum.*
 - *Signal protection by 256bit AES encryption (in UNICAST mode)*
 - *The adoption of 'MIMO', which multiplexes wireless signals via multiple antennas in one channel, enables HD-SDI or SD-SDI transmission.*
 - *Both automatic and manual selection of transmitted frequencies (4ch).*
 - *Two-level select (HIGH/LOW) of transmit output power.*
 - *Power can be supplied by V-Mount type Lithium Ion battery or by DC input, via XLR 4P connector.*
 - *Back up power failure function enables immediate and automatic switching to a connected battery if the external DC connected power is disconnected.*
-
- * *The transmission distance may vary depending on surroundings, radio wave conditions, buildings, etc., the transmission distance of approximately 50m is not guaranteed.*
 - * *When CW-5HD is placed near a device such a TV, the TV image may be disrupted. Please increase the distance between TV and CW-5HD when this happens*
 - * *In locations with many other devices operating in the 5GHz wireless bandwidth, CW-5HD operation can be affected, and images may be interrupted.*
 - * *Signal reception may be affected by the position, height and angle of placement. If reception is not stable, please physically adjust placement for the optimised signal.*

2. Getting Started

2.1. CW-5HD TX (Transmitter)

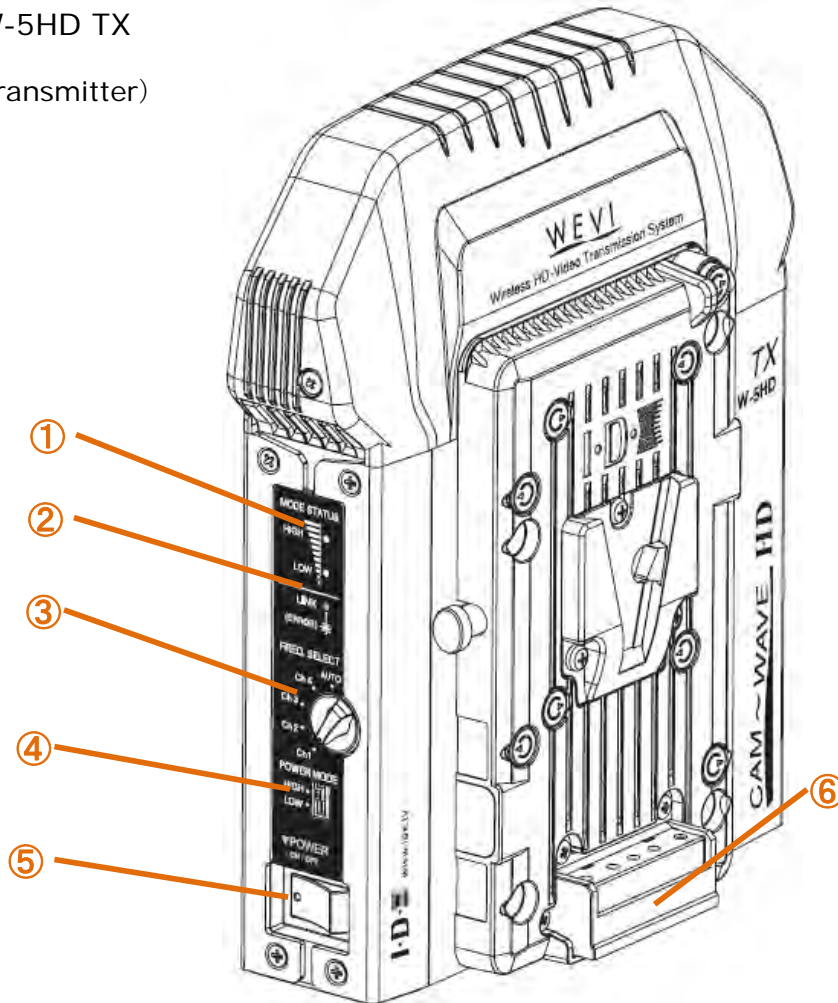

1. POWER MODE LED	Indicates selected power output mode
2. LINK STATUS LED	Indicates link status (Linked or Searching)
3. FREQ SELECT	Selects transmitted frequencies Manual selection : CH1~CH4 Automatic selection : AUTO In AUTO position, transmitted frequency is selected automatically.
4. POWER MODE	Selects transmitted output (HIGH/LOW)
5. POWER SW	Turns ON/OFF the power of CW-5HD TX.
6. V-Mount	Mounts V-Mount type Lithium Ion battery.

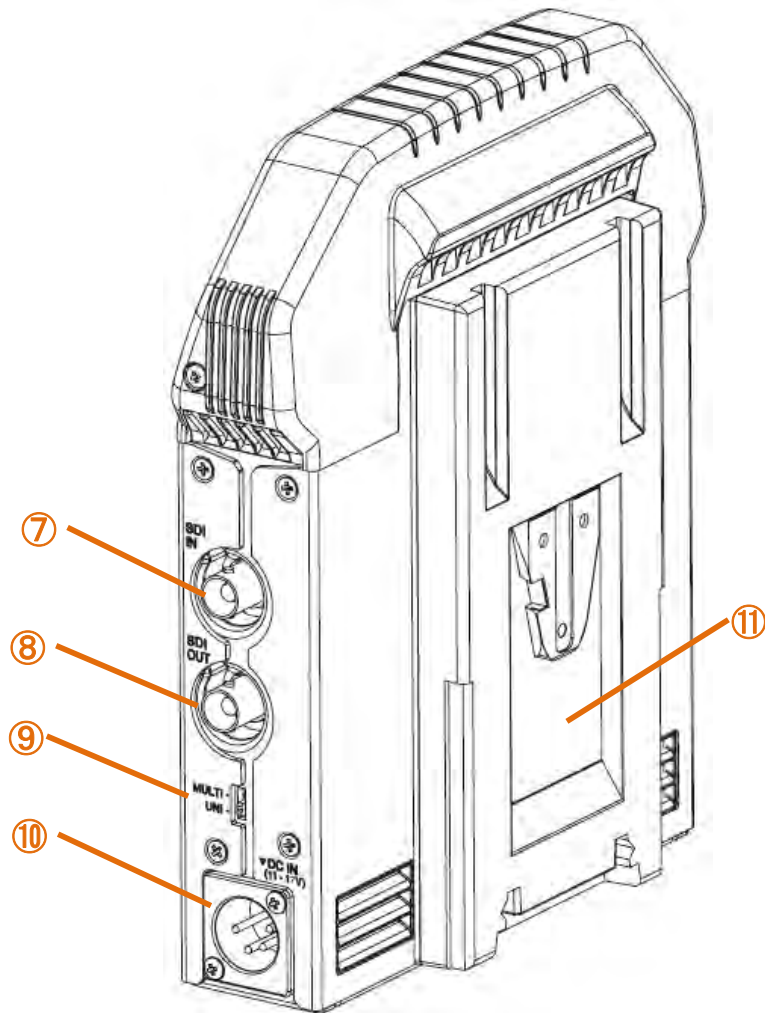

7. SDI IN	Connects to the video source's SDI output connector.
8. SDI OUT	Loop-outputs the input SDI signal. Used to allow for video monitoring on transmit side.
9. UNI/MULTI SW	Selects the link mode. <ul style="list-style-type: none"> ✧ UNI : Unicast mode ✧ MULTI : Multicast mode
10. DC-IN	Connect when external power supply is used. <ul style="list-style-type: none"> ✧ Connector XRL-4P male connector ✧ Input range DC 11~17V ✧ Pin assign No.1:negative(-) No.4:positive(+) ✧ <i>Powers CW-5HD only (does not power camera)</i>
11. V-Plate	Mounts CW-5HD TX to the V-Mount of selected source.

2.2 CW-5HD RX

(Receiver)

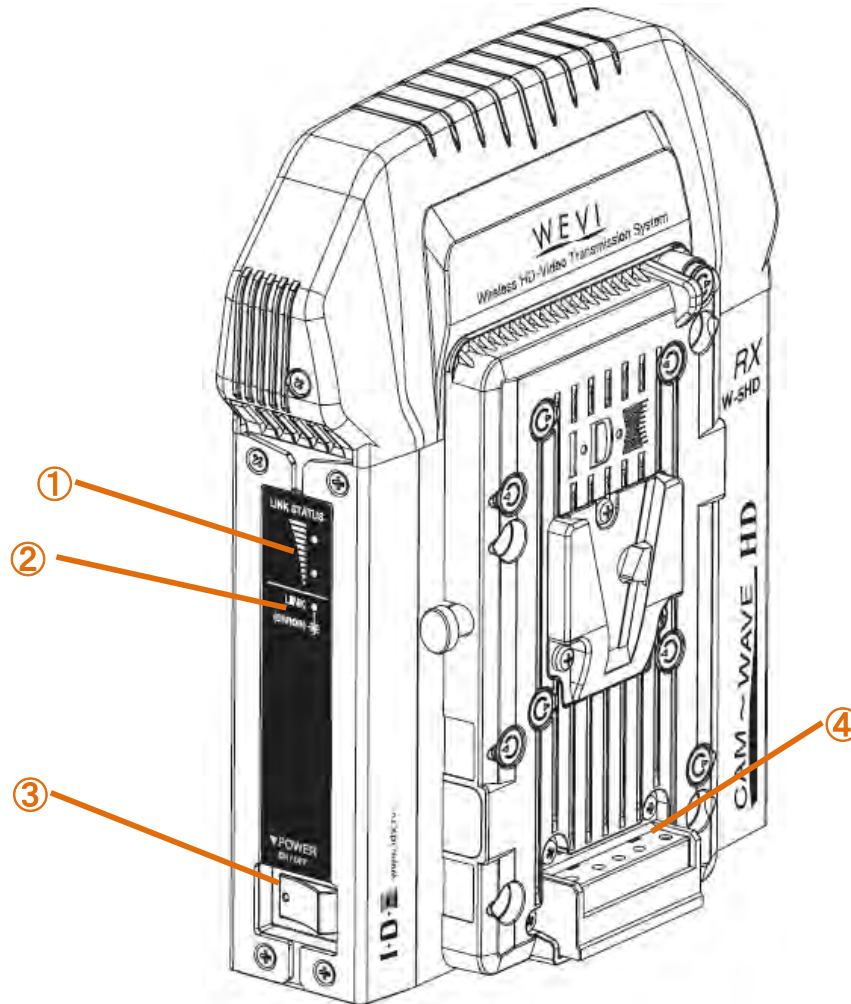

1. LINK LEVEL LED	Indicates intensity of received signal.
2. LINK LED	Indicates link status (Link on or Searching).
3. POWER SW	Turns ON/OFF the power of CW-5HD RX.
4. V-Mount	Mounts V-Mount type Lithium Ion battery.

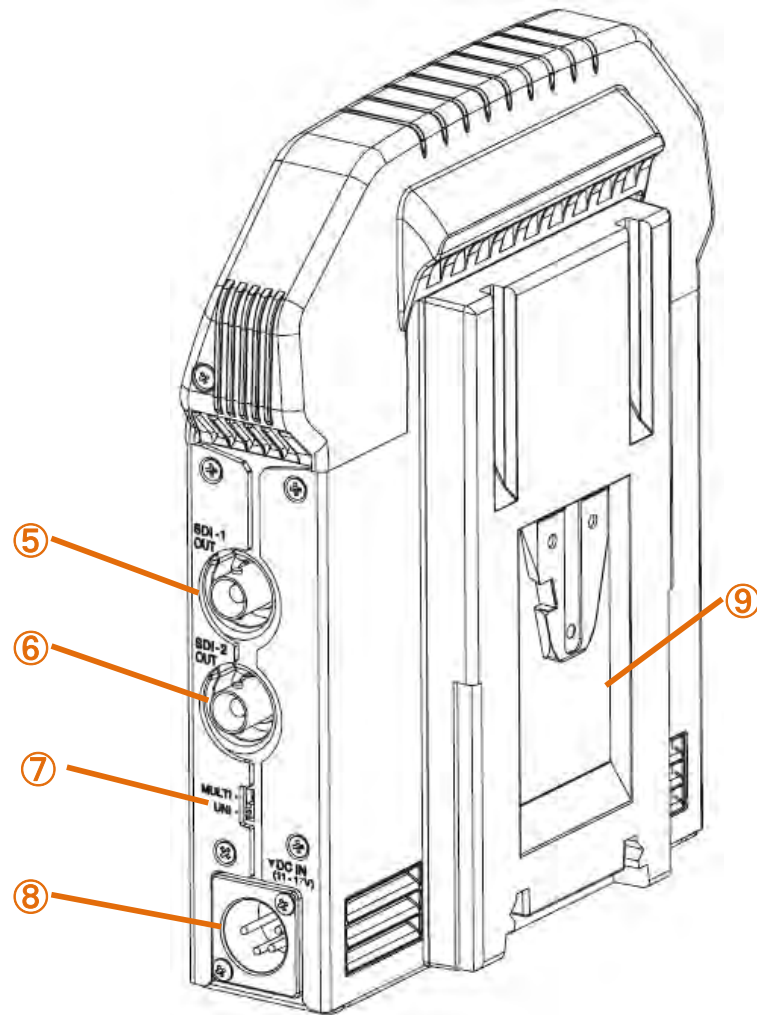

5. SDI-1 OUT	Connects to the video input connector of monitor, etc.
6. SDI-2 OUT	Connects to the video input connector of monitor, etc.
7. UNI/MULTI SW	Select link mode. <ul style="list-style-type: none"> ✧ UNI : Unicast mode ✧ MULTI : Multicast mode
8. DC-IN	Connects to external power supply. <ul style="list-style-type: none"> ✧ Connector : XRL-4P male ✧ Input range : DC 11~17V ✧ Pin assign No.1 : negative(-) No.4 : positive(+) ✧ <i>Powers CW-5HD only (does not power monitor)</i>
9. V-Plate	Mounts CW-5HD RX to V-Mount of selected device

3. LED indicators

3.1. LED indicator functions

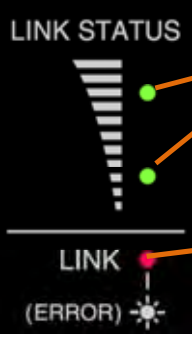
<p style="text-align: center;">TX</p>  <p>The TX LED indicator panel is divided into two sections. The top section, labeled 'MODE STATUS', contains a vertical bar with a gradient from dark to light, representing power levels. Two green LEDs are positioned to the right of this bar, with arrows pointing to them from the text in the adjacent cell. The bottom section, labeled 'LINK (ERROR)', contains a red LED and a white LED with a starburst symbol next to it, representing link status. An arrow points from the text in the adjacent cell to the red LED.</p>	<p>MODE STATUS LED</p> <p>Indicates the manually selected transmitted output power mode (HIGH/ LOW), and the UNICAST/MULTICAST setting.</p> <ul style="list-style-type: none"> ◇ POWER MODE HIGH : 2 lights on ◇ POWER MODE LOW : 1 light on ◇ UNICAST : LED light colour is Green ◇ MULTICAST : LED light colour is Amber
<p style="text-align: center;">RX</p>  <p>The RX LED indicator panel is divided into two sections. The top section, labeled 'LINK STATUS', contains a vertical bar with a gradient from dark to light, representing signal strength. Two green LEDs are positioned to the right of this bar, with arrows pointing to them from the text in the adjacent cell. The bottom section, labeled 'LINK (ERROR)', contains a red LED and a white LED with a starburst symbol next to it, representing link status. An arrow points from the text in the adjacent cell to the red LED.</p>	<p>LINK LED</p> <p>Indicates the link status.</p> <ul style="list-style-type: none"> ◇ Linked (no video signal) : Amber light on ◇ Linked (with video signal) : Green light on ◇ Error : Red light blinking <hr/> <p>LINK STATUS LED</p> <p>Indicates the strength of received signal while RX is linked and the (UNICAST/MULTICAST) setting.</p> <ul style="list-style-type: none"> ◇ Signal is strong : 2 lights on ◇ Signal is weak : 1 light on ◇ UNICAST : LED light colour is Green ◇ MULTICAST : LED light colour is Amber <hr/> <p>LINK LED</p> <p>Indicates the link status.</p> <ul style="list-style-type: none"> ◇ Linked (no video signal) : Amber light on ◇ Linked (with video signal) : Green light on ◇ Error : Red light blinking

3.2 CW-5HD Link Initialisation (common to TX/RX)

When the power switch of CW-5HD is turned on or the link of the transmitted signal is lost, the CW-5HD TX and CW-5HD RX will start to search for each other. The three LED lights will alternate on and off from bottom to top in sequence, repeating this process until a link is established. This LED alternating from bottom to top will indicate that the device is searching for a link.

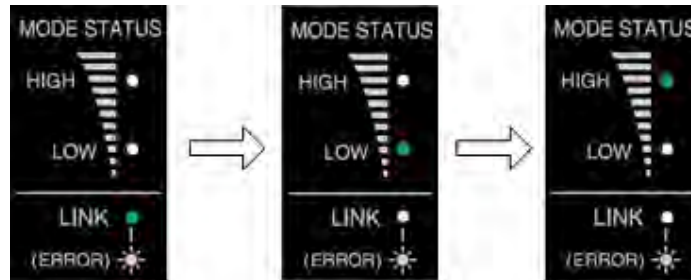

Searching (TX) : Green LED blinks on and off repeatedly

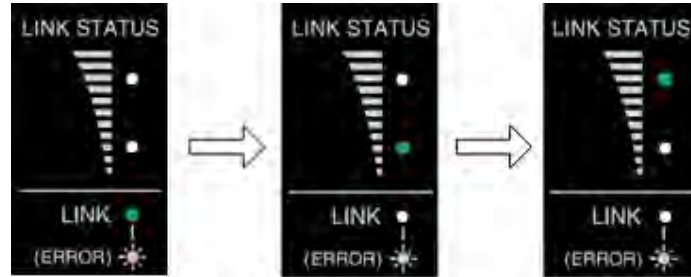

Searching (RX) : Green LED blinks on and off repeatedly

4. Selecting frequencies and power output

The CW-5HD TX is equipped with a FREQ SELECT switch and POWER MODE switch. With the FREQ SELECT switch, the transmitted frequency is set. The frequency selection is needed only on the TX. The frequency of the RX does not have to be selected because RX searches for the transmitted frequency automatically. POWER MODE switch changes the transmitted output to HIGH or LOW.

4.1. Service frequencies and transmitted output

The service frequencies and the maximum transmitted outputs of CW-5HD vary according to the designated regions.

The table below shows the service frequencies, corresponding channel positions and the transmitted outputs for the EU region.

Region	Channels	Service frequencies (MHz)	Transmitted power (HIGH Mode)	Transmitted power (LOW Mode)
Europe	CH1	5862.5MHz	50mW	5mW
	CH2	5180MHz	14.5mW	
	CH3	5200MHz		
	CH4	5220MHz		

4.2. Automatic frequency selection

With FREQ SELECT in AUTO position, CW-5HD automatically selects the channel according to the frequencies assigned to CH1 through CH4.

5. Link modes - UNICAST/MULTICAST

The UNI/MULTI switch is used to select the link mode. The UNI/MULTI select switches on both the CW-5HD TX and CW-5HD RX must be set in the same mode.

5.1. UNICAST mode (1:1 communication)

With UNI/MULTI switch in UNI position, CW-5HD links in UNICAST mode. In UNICAST mode, the link is made only between the same serial numbered pair of TX and RX (shipped as a pair). The transmitted signals are encoded by 256bit AES and can never be intercepted by other CW-5HD devices.

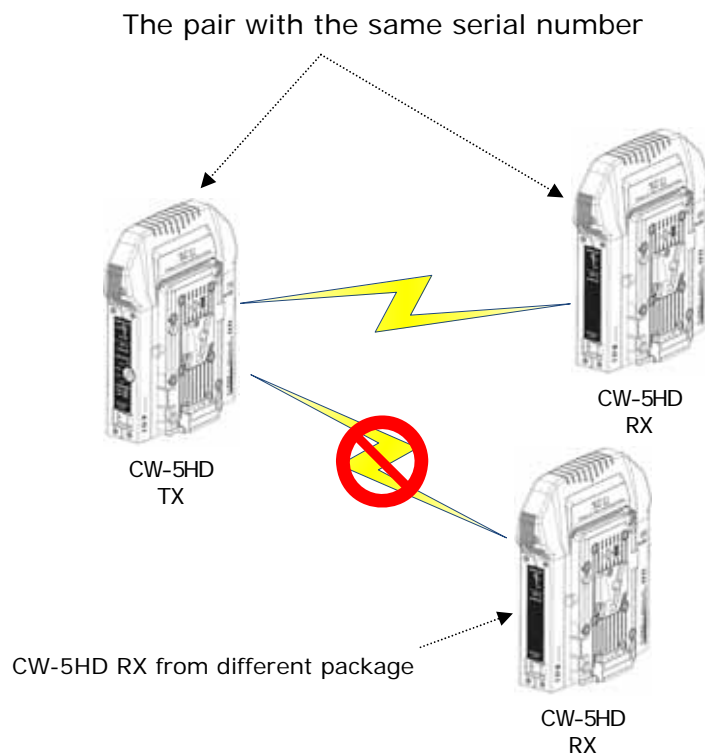

The link in UNI position

5.2. MULTICAST mode (1:n communication)

With the UNI/MULTI switch in MULTI position, the CW-5HD links in MULTICAST mode, in which the CW-5HD TX can send video and audio to more than one CW-5HD RX. In MULTICAST mode, the transmitted signals are not encoded by 256bit AES encryption.

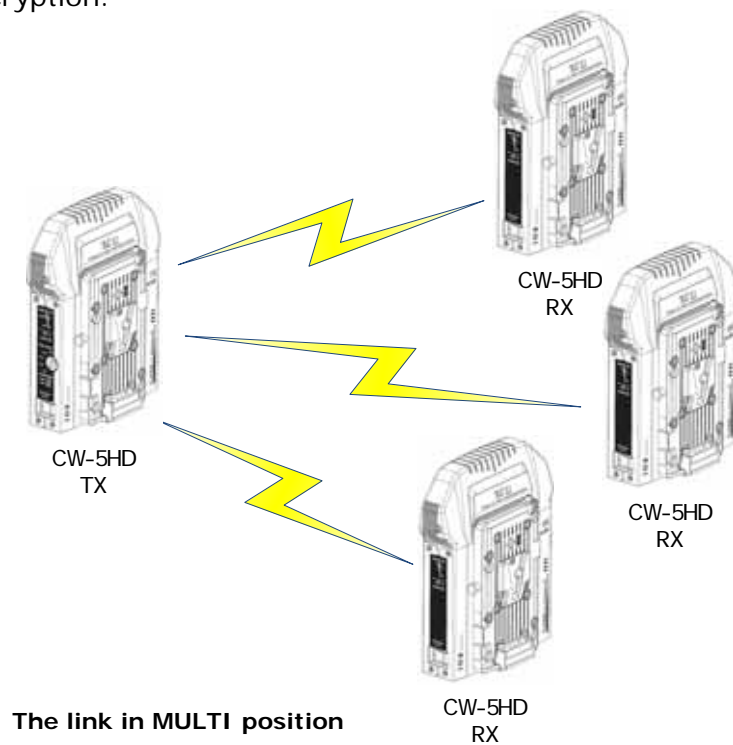

There is no limit on the number of receiving CW-5HD RX in MULTICAST mode as long as they are within reach of the transmitted signal and existing environmental conditions are taken into regard.

Important Notes

- When more than one CW-5HD TX are transmitting in MULTICAST mode in the same location, the CW-5HD RX will link with the first signal that it receives.
- A single CW-5HD RX can not receive the signal from more than one CW-5HD TX.

6. Operation guide

6.1. Set up

The CW-5HD does not include the various accessories that may be used in its operation. Please separately access the following items as needed for your specific application prior to use.

- BNC cable for HD-SDI or SDI signal connectivity
- IDX ENDURA system batteries or external power supply

Note: Power supply; Use only an AC adaptor, or batteries, with a DC output of 11V – 17V. The CW-5HD DC-IN connector is XRL-4P male, pin assign no.1: negative (-), no.4: positive (+). Do not apply over-voltage or reverse-polarity voltage since they can cause failure or damage.

6.2. Operating procedures

- ① Connect CW-5HD TX to the video camera or other transmitting devices battery source and CW-5HD RX to the receiving monitor's battery mount. If either device does not have a V-Mount, use the applicable adapter.
- ② Connect video device's SDI output connector to CW-5HD TX SDI input connector with a BNC cable. Next, connect the CW-5HD RX SDI output connector to the monitor's SDI input with BNC cable.
The CW-5HD TX has an SDI output connector, which can be connected to a monitor for the video source if required. The CW-5HD RX has two output connectors therefore two monitors, recorders, etc can be connected simultaneously.
- ③ Connect fully charged ENDURA batteries to CW-5HD TX and CW-5HD RX. When an external power supply is used, connect to DC-IN connector.
Note: *When an ENDURA battery is used, power is supplied to both CW-5HD and video camera / monitors etc. When external power supply is used at the DC-IN XLR, power is supplied only to CW-5HD. Video camera, monitors etc must be powered from another source.*
- ④ Set the FREQ SELECT switch, POWER MODE switch, UNI/MULTI switch of CW-5HD TX in appropriate modes. Set the UNI/MULTI switch of CW-5HD RX in appropriate mode.
- ⑤ Turn the power ON.

6.3. If reception is unstable

Signal reception may be affected by the position, height and angle of placement. If reception is not stable, please look for the best condition by adjusting the location, height, and other environmental variables.

When CW-5HD TX and RX are used close to each other, the received signal becomes too strong and may disturb the video signal. When they are placed close to each other (less than 3m as an example), set the POWER MODE switch of CW-5HD TX to LOW.

6.4. Back-up power failure function

When an external power supply is used, power failure can be avoided by mounting an IDX ENDURA battery to CW-5HD at the same time. If the external power supply fails, use can continue via battery power. Depending on certain conditions, video quality may be momentarily affected.

6.5. Power through function

When the CW-5HD is used with ENDURA batteries, the power supply to the video camera, monitor, etc. will not stop even when the CW-5HD power switch is turned off.

If the CW-5HD is not actually required for transmission it can remain on the video source and turned off. The power from the attached battery will still power the device even though the CW-5HD is turned off, saving battery consumption.

7. Notes on Use

- (1) The service frequencies and transmit power outputs of CW-5HD vary depending on the designated regions, because each region has different local regulations or restrictions on radio waves. The units are

programmed in the factory prior to shipping. Therefore, a CW-5HD shipped to one region can not be used in a different region.

Regions	Channels	Service frequencies	Outdoor usage
Europe	CH1	5862.5MHz	Allowed
	CH2	5180MHz	Not allowed
	CH3	5200MHz	
	CH4	5220MHz	

- (2) Outdoor usage of the 5GHz

frequency band, which the CW-5HD uses, is controlled by region. This table shows the approved frequencies and the corresponding channels of CW-5HD in the EU region.

- (3) The maximum transmission distance varies depending on the surroundings, radio wave conditions, buildings structural composition etc. Although the indoor transmission distance is indicated as 30m (with CH1, POWER MODE=HIGH), however this is not a guaranteed operational level.
- (4) When the CW-5HD TX and RX are located close to each other, the received signal may be too strong and may disturb the video. When the CW-5HD TX and RX are used close to each other (say 3m or less as an example), set the POWER MODE switch of CW-5HD TX in LOW mode.
- (5) CW-5HD can not be equipped with external antennas.
- (6) The V-Plate connecting CW-5HD to video cameras, monitors, etc. does not have Digi-View series II capability for an ENDURA series battery. Therefore, CW-5HD can not support the battery's digital communication between an ENDURA battery and video camera.
- (7) The SDI output of CW-5HD conforms to SMPTE-292M/SMPTE-259M. However, in some linked conditions, clock jitter of SDI signals may exceed the regulated values.
- (8) CW-5HD uses SDI embedded audio, however only Audio channels 1 and 2 can be transmitted.
- (9) It should be understood that the quality level of video transmitted by wireless signal is not as good as that by hard-wired cable signals.

III. Specifications

8. CW-5HD TX

Video / Audio	
Video input signal	HD-SDI (conforms to SMPTE 292M) SD-SDI (conforms to SMPTE 259M-C)
Video input connector	BNC 1 type
Video output connector	BNC 1 type (input signal direct loop through)
Audio input signal	SDI Embedded (only CH1,CH2 transmitted)
Video format	HD : 1080i/59.94, 1080i/50, 1080p/29.97, 1080p/23.98, 720p/59.94, 720p/50 SD : 525i/59.94 (NTSC or equivalent), 625i/50 (PAL or equivalent)
Radio	
Frequencies	5GHz band EU version : CH1: 5862.5MHz, CH2: 5180MHz, CH3: 5200MHz, CH4: 5220MHz Channels are selected automatically or manually.
Transmitted output	HIGH/LOW 2 step manual select ※Outputs of HIGH position vary depending on region and frequencies. EU version : HIGH: 17dBm/ approx. 50mW (5862.5MHz) 11.6dBm/ approx.14.5mW (5180MHz-5220MHz) LOW: 7dBm/approx. 5mW
Transmitting system	MIMO / OFDM / JSCC
Antenna	Built-in pattern antennas - 2dBi each
Number of antennas	Down-link x4 and Up-link x1

Display / Operation	
Power switch	Power ON/OFF Input battery power runs through to the output side when the power is OFF.
Frequency selector	5-position rotary switch selecting CH1, CH2, CH3, CH4, AUTO
Transmitted output switch	Slide switch shifting HIGH/LOW
UNI/MULT switch	Slide switch UNI/MULTI UNI : Unicast mode (1:1 communication / encrypted) MULTI : Multicast mode (1:n communication / not encrypted)
Status indicator	LED in 2 colours: Red, Green ×3
Power	
Power supply	Battery in : 11-17V (using P-V2 IDX V-Mount) DC in : 11-17V [XLR-4 male: No.1 negative (-)/ No.4 positive (+)]
Power output	V-Plate (IDX A-NH2E or equivalent)
Applicable batteries	IDX ENDURA series Li-ion batteries Battery input power runs through out to the transmitting device. Automatically switched to battery supply if DC supply fails.
Physical Characteristics	
Size	Width 158mm (6.22") Depth 72mm (2.83") Height 188mm (7.40")
Weight	800g approx. (1.76lbs approx.)
Power consumption	12W max. (approx.)
Operation temperature	0~40°C (No Dew)
Approved standards	CE: ETSI EN 301 893, ETSI EN 302 502, ETSI 301 489-17 FCC: Part 15C, Part 15E

9. CW-5HD RX

Video / Audio	
Video output signal	HD-SDI (conforms to SMPTE 292M) SD-SDI (conforms to SMPTE 259M-C)
Video output connector	BNC 2 type (direct loop-through of the input signal)
Audio output signal	SDI Embedded (only CH1,CH2 are transmitted)
Video format	HD : 1080i/59.94, 1080i/50, 1080p/29.97, 1080p/23.98, 720p/59.94, 720p/50 SD : 525i/59.94 (NTSC or equivalent), 625i/50 (PAL or equivalent)
Radio	
Frequencies	5GHz band EU version : CH1: 5862.5MHz, CH2: 5180MHz, CH3: 5200MHz, CH4: 5220MHz Channels are selected automatically or manually.
Transmitted output	Uplink output in Unicast mode Automatically set according to the output from CW-5HD TX.
Transmitting method	MIMO / OFDM / JSCC
Antennas	Built-in pattern antennas - 2dBi each
Number of antennas	Downlink x 5 and Uplink x 1
Display / Operation	
Power switch	Power ON/OFF Battery input goes through to output side even when the power is OFF.
UNI/MULT switch	Slide switch UNI/MULTI UNI : Unicast mode (one-to-one link / encrypted) MULTI : Multicast mode (one-to-multiple links / not encrypted)
Status indicator	LED in 2 colours; Red, Green) ×3

Power	
Power supply	Battery input : 11-17V (using P-V2 IDX V-Mount) DC input : 11-17V [XLR-4 male : No.1 negative (-)/ No.4 positive (+)]
Power output	V-Plate (IDX A-NH2E or equivalent)
Applicable batteries	IDX ENDURA System Li-ion batteries Battery input power is connected directly to camera side V-Mount. Automatically switches to battery supply when DC supply failed.
Physical Characteristics	
Size	Width 158mm (6.22") Depth 72mm (2.83") Height 188mm (7.40")
Weight	800g approx. (1.76lbs approx.)
Power consumption	12W Max. (approx.)
Operating temperature	0~40°C (No Dew)
Approved standards	CE: ETSI EN 301 893, ETSI EN 302 502, ETSI 301 489-17 FCC: Part 15C, Part 15E