

cev.fr

ADC-800 CAM

HDV Camera HD/SD A-to-D Converter

Guide to Installation and Operation

M822-9900-101

8 Aug 2007



Miranda

Technologies Inc.

3499 Douglas-B.-Floreni

St-Laurent, Québec, Canada H4S 1Y6

Tel. 514-333-1772

Fax. 514-333-9828

www.miranda.com

© 2007 Miranda Technologies Inc
Specifications may be subject to change

Table of Contents

1	ADC-800 CAM: HDV Camera HD/SD A to D Converter.....	1
1.1	Introduction	1
1.2	Features	1
1.3	Functional Block diagram.....	2
1.4	Application Example	2
2	Installation	3
2.1	Physical Installation	3
2.2	Connectors and Controls	3
2.3	Signal Connections	5
2.4	Power Supply	5
3	Operation	6
3.1	User Interface.....	6
3.2	Power Management.....	6
3.3	Video Input	6
3.4	Audio Input	7
3.5	Time Code.....	8
3.6	Camera Status	8
3.7	Detail Enhancer.....	8
3.8	Test Signals	8
3.9	On-Screen Display	9
4	Specifications.....	10

1 ADC-800 CAM: HDV Camera HD/SD A to D Converter

1.1 Introduction

The ADC-800 CAM is a compact, camera-mounted interface that allows live HD digital monitoring and recording from an HDV camcorder. This is achieved by converting the EE uncompressed component analog output to HD-SDI, with left/right audio and time code embedded. This path overcomes the processing delay inherent with the MPEG2 long GOP structure, which makes it inappropriate to use the HDV stream for live monitoring. This process also reduces the number of cables required for recording. The ADC-800 CAM also provides separate on-screen display, including markers, time code burn-in and peak meters.

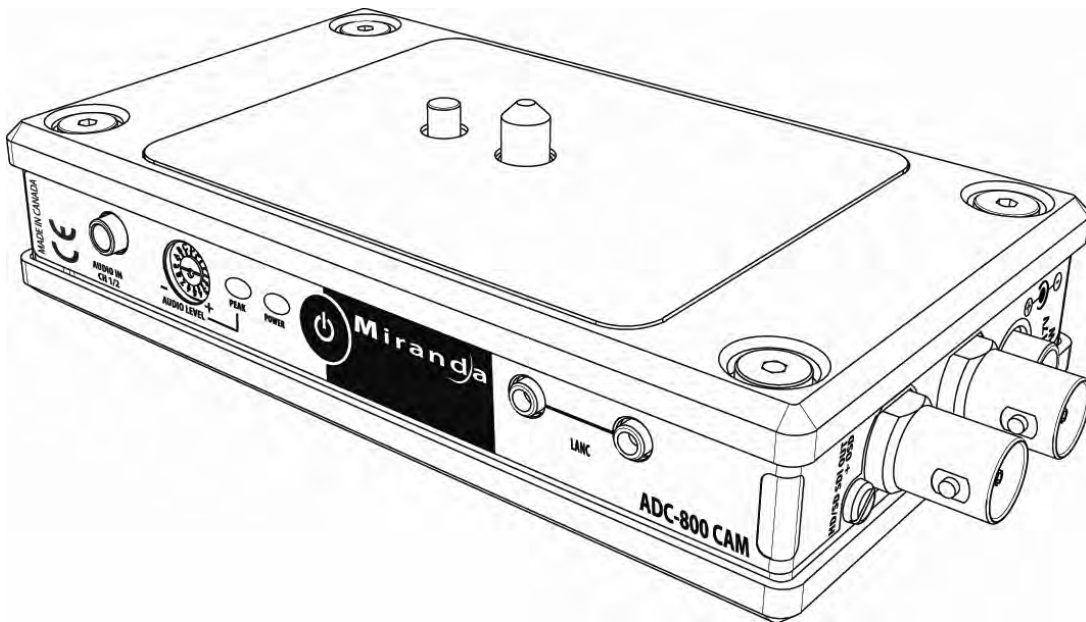

1.2 Features

- HD/SD 10-bit component analog video to digital converter
- HD/SD SDI output with audio and time code embedded
- On-Screen Display (OSD) provides Time code burn-in, 4:3 Aspect Ratio markers, audio peak meters and camera status
- Time code can be extracted from LANC or LTC
- Supported Formats:
 - SD 525/625
 - HD 720p 50, 59.94
 - HD 1080i 50, 59.94
- Detail enhancer
- Compact camera-mounted design
- Wide input power range of 6V to 17V

1.3 Functional Block diagram

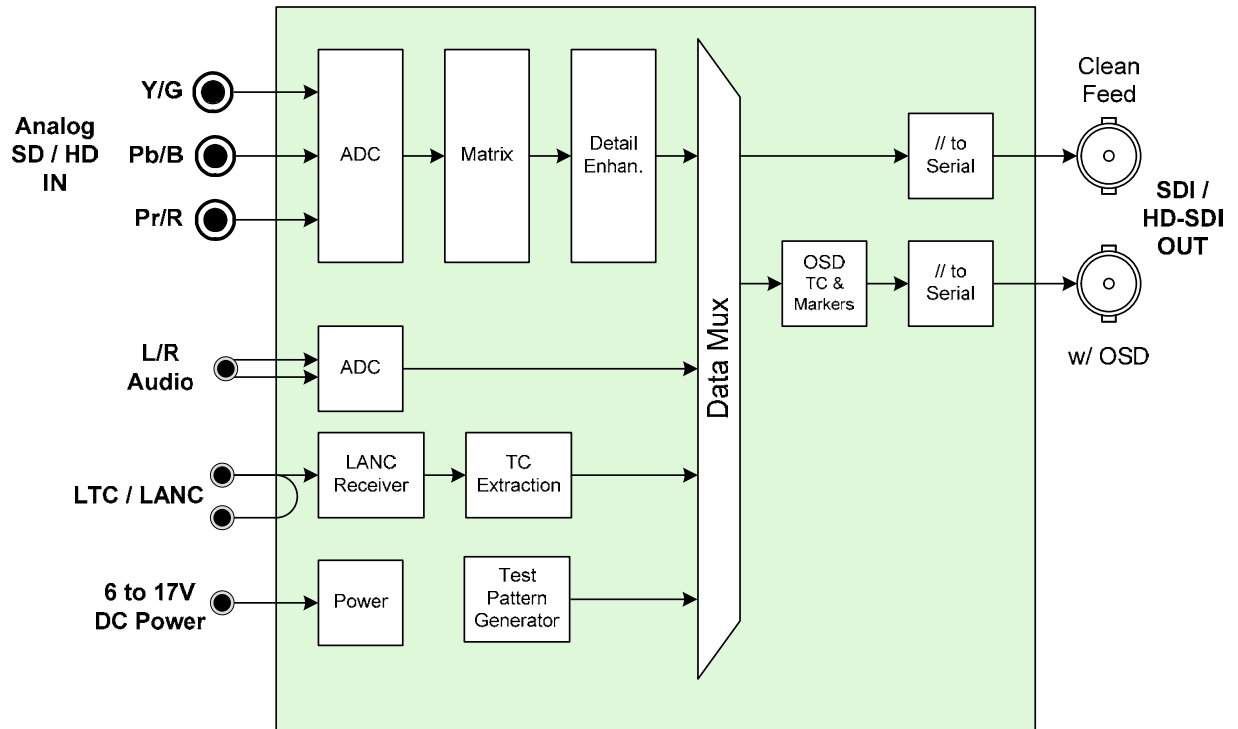

Figure 1.1 Functional block diagram of the ADC-800 CAM

1.4 Application Example

Here is a typical setup using the ADC-800 CAM.

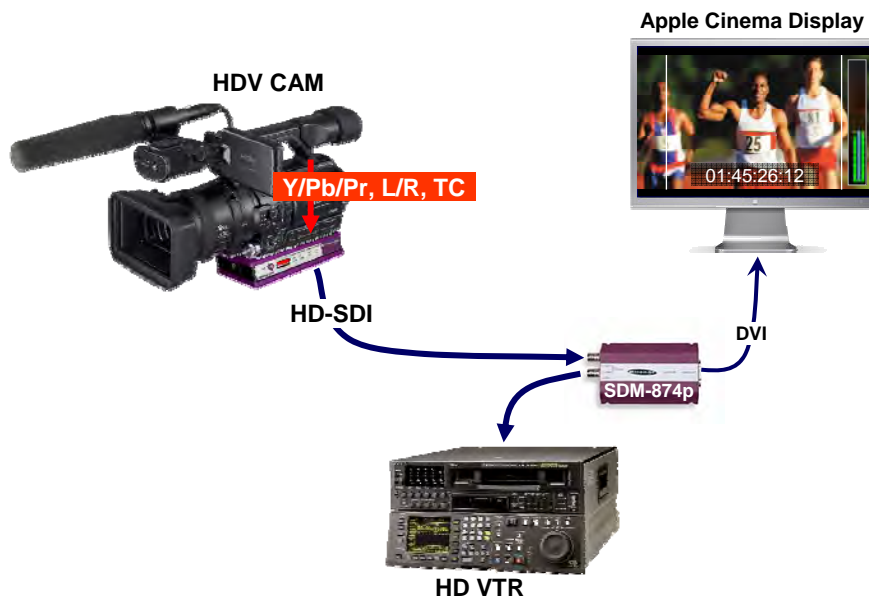

Figure 1.2 Application example

2 Installation

2.1 Physical Installation

The ADC-800 CAM mounts on the base of the camera, between the camera and its tripod or shoulder mount.

- ♦ Remove the camera from its tripod or shoulder mount
- ♦ Install the ADC-800 CAM onto the tripod mount on the base of the camera using the captive bolt
- ♦ Reinstall the tripod or shoulder mount, using the mounting hardware on the bottom of the ADC-800 CAM.

2.2 Connectors and Controls

Refer to figure 2.2 and to the descriptions below when connecting the ADC-800 CAM.

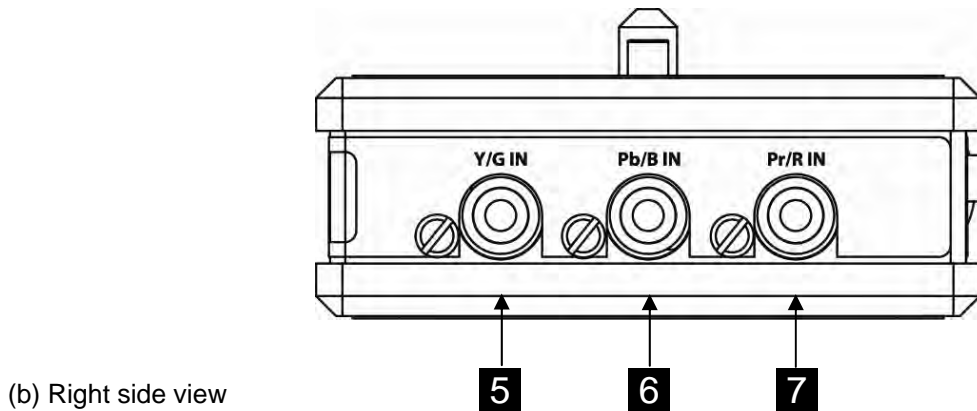
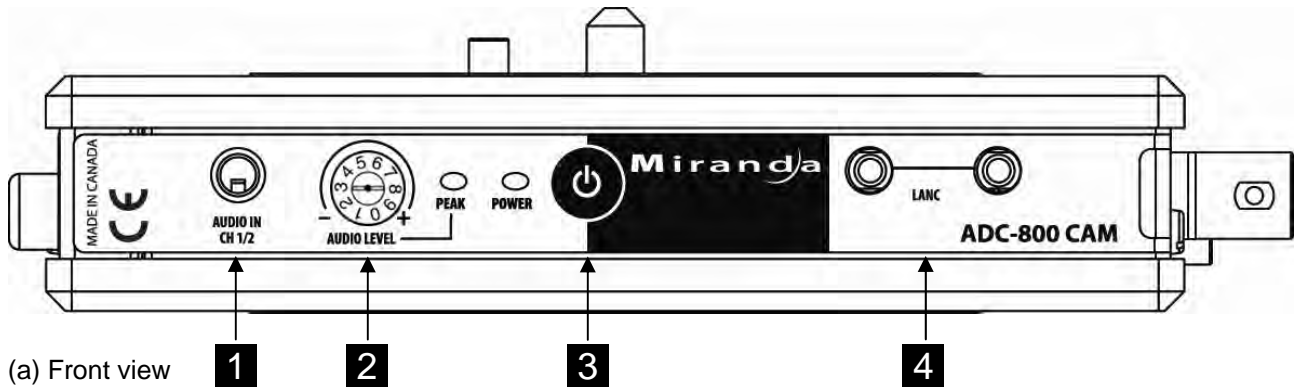

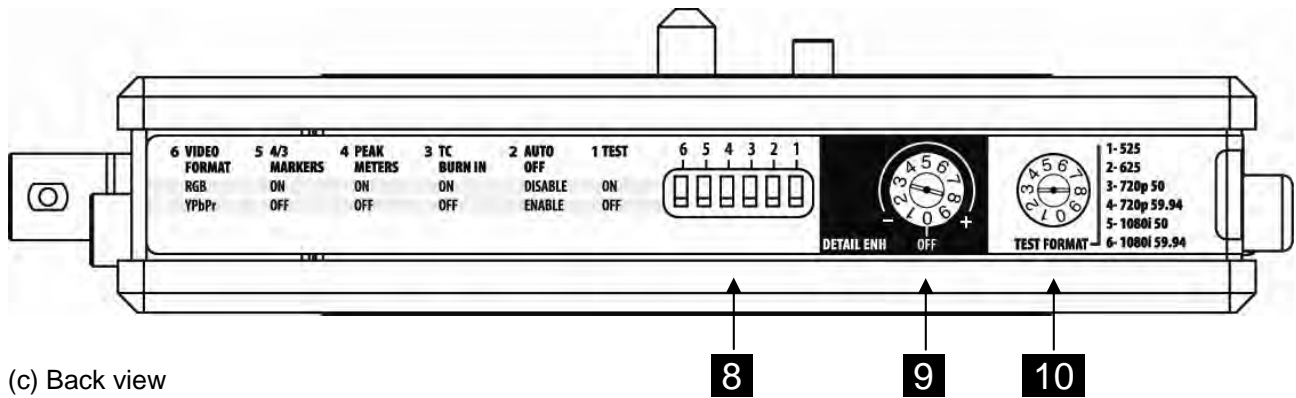

(c) Back view

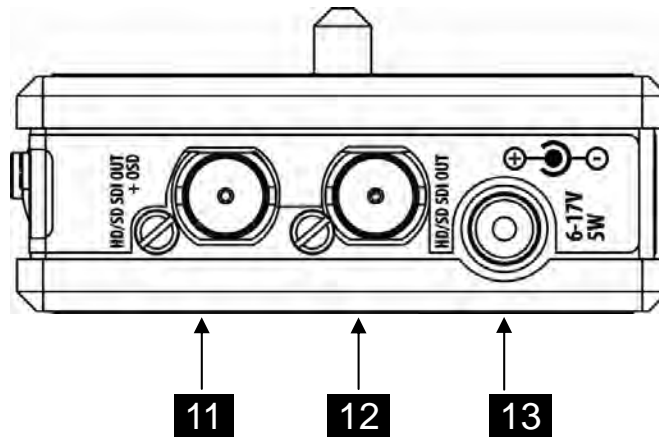

(d) Left side view

Figure 2.2 (a) Front, (b) Right side, (c) Back, (d) Left side views of the ADC-800 CAM

- 1** Analog Audio IN (Ch. 1 & 2 on a 3.5mm stereo jack) – Connect to the camera audio output for Channels 1 & 2
- 2** Audio Ch 1/2 Level Control & peak LED – use to adjust and monitor peaks on the analog audio Ch 1/2 input (see section 3.3)
- 3** Power Button – push ON / push OFF (see section 3.2)
- 4** LANC or LTC input and loop-through (2.5mm mini stereo jacks) – auto-detection of signal type
- 5** Y/G – analog component input
- 6** Pb/B – analog component input
- 7** Pr/R – analog component input
- 8** DIP Switches – use to set up some operating parameters (see sections 3.2 – 3.6, 3.8 and 3.9)
- 9** Detail Enhancer level
- 10** Test format selection
- 11** HD/SD SDI OUT +OSD – output with burned-in OSD (see sect. 3.9)

12 *HD/SD SDI OUT* – clean feed

13 *Power IN* – connect an appropriate DC power supply (see Section 2.4 – Power Supply)

2.3 Signal Connections

Use the cables supplied with your ADC-800 CAM to connect the audio and LANC or LTC outputs from the HDV camera to the appropriate connectors on the ADC-800 CAM (items 1 and 4 above).

Audio Cable: 3.5 mm jack, wired as shown

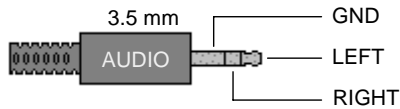

LANC / LTC cable: 2.5 mm jack, wired as shown

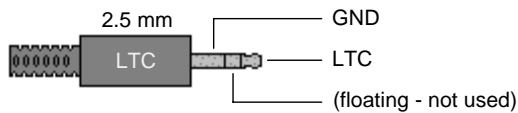
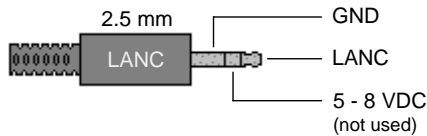

Use appropriate video cables (not supplied) to connect the component video signals from the camera output to the ADC-800 CAM video inputs (items 5, 6 and 7 above).

2.4 Power Supply

The ADC-800 CAM is not shipped with a power supply, since operational considerations will usually dictate power supply requirements. The power entry to the ADC-800 CAM is via a lockable jack, to provide protection against accidental disconnects in operation, and the jack is provided.

- The supply should be rated at 6-17 VDC, 5W

Wire the supply to the connector as shown on the ADC-800 CAM case, i.e. 

3 Operation

Turn the ADC-800 CAM ON using the front-panel power button (see fig. 2.2 (a) and section 3.2)

3.1 User Interface

The ADC-800 CAM user interface consists of:

- an ON/OFF pushbutton with status LED **3** (see section 3.2)
- an audio level control with a peak-indicating LED **2** (see section 3.4)
- a detail enhancer level control **9** (see section 3.7)
- a Test signal format selector **10** (see section 3.8)
- six DIP switches to set various operating modes **8**

See figure 2.2 to find the location of these controls.

3.2 Power Management

The ADC-800 CAM has three power modes:

OFF The unit is OFF when:

- No power supply is connected to the power input on the rear panel
- Power is connected and the Power Status LED is not illuminated

Switch the unit between OFF and ON modes using the power button.

ON The unit is ON when:

- Power is connected and the Power Status LED is illuminated

Switch the unit between ON and OFF modes using the power button.

AUTO OFF The AUTO OFF mode is selected by placing DIP switch #2 in the *Enable* position

- AUTO OFF mode switches the ADC-800 CAM from ON to OFF automatically if no video input signal is detected for a period of 15 seconds, preserving battery power in some operational environments.
- Disable the AUTO OFF mode if occasional no-signal time intervals are expected and you want the unit to remain ON.

Disable the AUTO OFF mode by placing DIP switch #2 in the *Disable* position

3.3 Video Input

The ADC-800 CAM accepts analog component video on its three input connectors.

The format is switchable between Y Pr Pb and RGB.

- Use DIP switch # 6 to select the appropriate format to match the camera output.

The video standard is auto-detected if it conforms to one of the following:

- 525
- 625
- 720p 50
- 720p 59.94
- 1080i 50
- 1080i 59.94

3.4 Audio Input

The ADC-800 CAM has a single audio input, connecting to the analog audio outputs on the HDV camcorder. This input accepts an audio stereo pair, and is labeled Ch 1&2.

These signals are embedded into the digital data stream at the ADC-800 CAM output.

As this is an analog input, it is provided with a level adjustment and a peak-indicating LED.

- The LED shows Yellow at -3 dBFS, and Red when the signal reaches 0 dBFS

The level adjustment control is a rotary switch. It attenuates the input signal according to the following chart:

Audio Level Control Settings	
Switch	Attenuation
0	0.0 dB
1	-0.3 dB
2	-0.5 dB
3	-1.0 dB
4	-2.0 dB
5	-3.0 dB
6	-5.0 dB
7	-6.0 dB
8	-10.0 dB
9	-30.0 dB

- If necessary, adjust the level up until the peak LED illuminates on loud signal peaks, and then back off the level until the LED no longer illuminates

The OSD display can incorporate a graphic rendition of an audio peak meter. It appears as a vertical bar graph indicating left and right signal level with a warning LED at the top of each bar. The warning LED appears YELLOW when audio peaks reach -3 dBFS, and RED when audio peaks reach 0 dBFS, mimicking the Audio Level Peak LED on the ADC-800 CAM front panel.

- Use DIP switch #4 PEAK METERS to turn the OSD meter ON or OFF

The audio is embedded into the ADC-800 CAM's outputs at all times; DIP switch #4 only affects the on-screen display of the audio meters

NOTE that this DIP switch also controls the display of Camera Status information in the OSD, as described in Section 3.6.

3.5 Time Code

The ADC-800 CAM accepts time code output from the camcorder, either from the LTC output or the LANC output. The time code is looped through so it remains available at the camera for other purposes. If no valid time code is present at the ADC-800 CAM input, it will generate its own internal time code.

Time code is burned into the center-bottom position, semi-transparent.

- Use DIP switch #3 TC BURN-IN to turn the OSD time code display ON or OFF

The time code is embedded into the ADC-800 CAM's outputs at all times; DIP switch #3 only affects the on-screen display of the time code.







3.6 Camera Status

The LANC connection from the camera carries Camera Status information. This information can be extracted and displayed in the output as part of the OSD.

- DIP switch #4 PEAK METERS turns the status display ON or OFF

NOTE that this DIP switch also controls the display of the Peak Meters, as described in Section 3.4.

The status is displayed in the form of icons, and shows the current operating mode of the camera's integrated recorder.

MODE	ICON	MODE	ICON
PLAY		RECORD	
PAUSE		FAST FORWARD	
STOP		REWIND	

If the LANC input is connected to an LTC signal, Camera Status will not appear in the OSD.

3.7 Detail Enhancer

As the ADC-800 CAM processes analog inputs, it is sometimes useful to be able to sharpen the picture. The built-in detail enhancer serves this purpose.

- Use the rotary Detail Enhancer switch **9**
- The control settings range from 0 to 9, in arbitrary units; 0 corresponds to OFF
- Adjust the level of enhancement subjectively, while viewing the output of the ADC-800 CAM on a high-quality monitor

3.8 Test Signals

The ADC-800 CAM can output test signals instead of the input video and audio from the camera.

Place DIP switch #1 in the ON position to output these signals:

- Video – Color bars 75% white with white square for 16:9 / 4:3 aspect ratio.
- Audio – Audio tone -18 dBFS, 20 bit, 1 KHz continuous tone on right channel with pulsed tone on left channel

The signals are locked to an internal generator, and the format is selected from the following options using the Test Format selector **10**.

- 525
- 625
- 720p 50
- 720p 59.94
- 1080i 50
- 1080i 59.94

3.9 On-Screen Display

The on-screen display (OSD) is burned into the ADC-800 CAM's HD/SD SDI + OSD output. Various elements can be turned ON or OFF using the DIP switches shown in figure 2.2(c) **8**.

Markers – grey-line markers are available in 4:3 pillarbox for HD format only. There are no markers for SD signals.

- Use DIP switch #5 to turn the markers ON or OFF

Audio Meters (see section 3.4 above) and **Camera Status** (see section 3.6 above)

- Use DIP switch #4 to turn the Audio Peak Meters and the Camera Status (via LANC) ON or OFF

Time code – see section 3.5 above

- Use DIP switch #3 to turn time code burn-in ON or OFF

This image shows the configuration of the Markers, Time Code, Audio Peak Meters and Camera Status indicator when all OSD elements are switched ON:

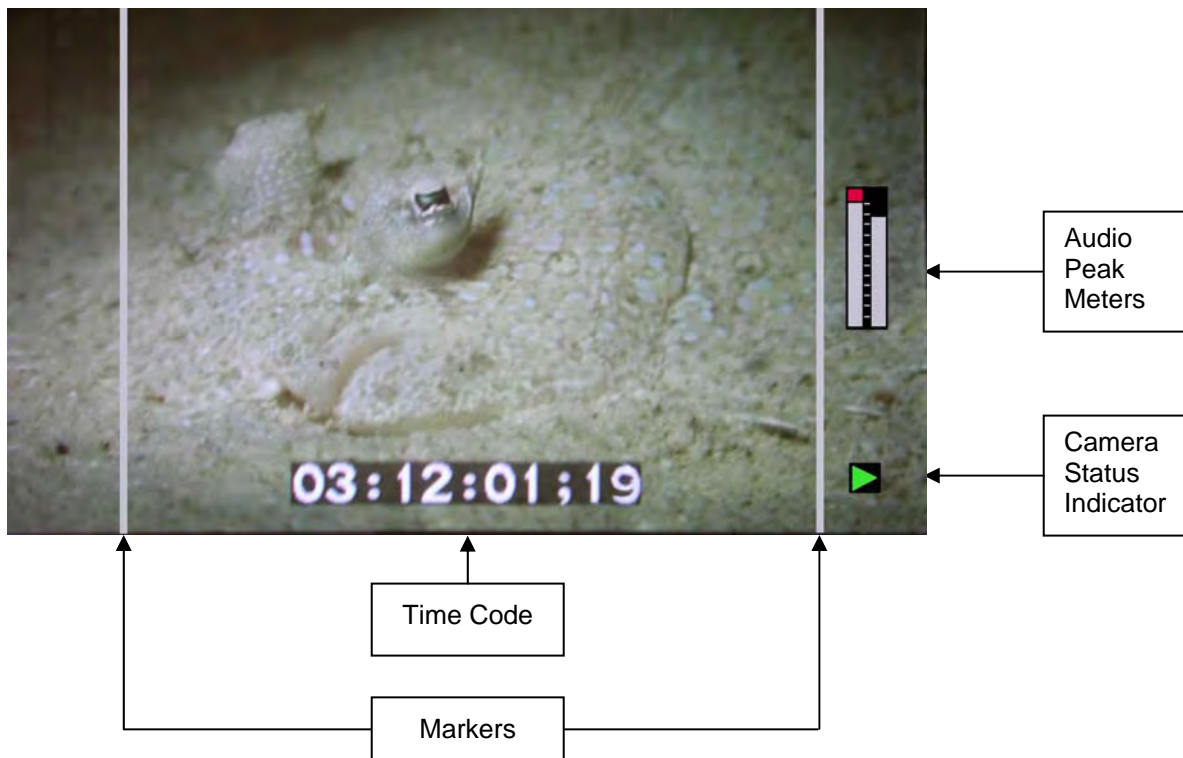

4 Specifications

INPUTS:

HD/SD CAV

SIGNAL	G/Y, B/Pb, R/Pr 1.0 Vp-p nominal (with sync on G/Y)
RETURN LOSS	> 20 dB up to 30 MHz
FREQUENCY RESPONSE	<1 dB up to 20 MHz for Y channel <1 dB up to 13.5 MHz for color channels
CONNECTORS	(3) black RCA

TIME CODE / CONTROL

SIGNAL	Open Collector
PROTOCOL	As per Sony Control L (LANC)
CONNECTORS	(2) 2.5mm mini stereo Jack

AUDIO

SIGNAL	Stereo Unbalanced Line In
LEVEL	Full Scale range = 3.2 – 10Vp-p
IMPEDANCE	> 10 K Ω
CONNECTOR	(1) 3.5mm stereo Jack

OUTPUTS:

HD/SD SDI OUTPUTS (2)

SIGNAL	SMPTE 292M (1.485, 1.485/1.001 Gbps) SMPTE 299M SMPTE 259M (270 Mbps) SMPTE 272M-A, SMPTE 291M
JITTER	<0.2 UI, 100KHz (HD) <0.2 UI wideband (SD)
RETURN LOSS CONNECTORS	> 15dB up to 1.5GHz (2) 75 Ω BNC

PROCESSING PERFORMANCE

VIDEO	10-bit HD SDI, 10-bit SD SDI, 12-bit sampling 27 MHz, 74.17 MHz, 74.25 MHz
STANDARD	1080i50, 1080i59.94, 720p50, 720p59.94, SD 525/60 and 625/50
AUDIO	24-bit HD SDI, 24-bit SD SDI, 24-bit Sampling 48 KHz locked

ELECTRICAL

POWER INPUT RANGE	6 to 17 VDC
POWER CONSUMPTION	< 5W

TEMPERATURE RANGE 0-40 °C

OTHER

TEST PATTERN Color bars 75% white with white flashing square for 16:9 / 4:3 aspect ratio.

AUDIO TONE -18 dBFS, 20 bit, 1 KHz continuous tone on right channel with pulsed tone on left channel in sync with white square